

# Calipers

For everyday applications



# The essential instrument

Calipers are the most popular measuring instruments used worldwide. Owing to their simple construction, ease of handling and secure operation, they are highly appreciated by all kinds of users.

With its wide variety of models, TESA offers everyone the opportunity to find the right instrument to meet all their metrological needs. Dial, digital or vernier? With or without data transmission capabilities? For which application types? These are typical requests that the full range of TESA calipers satisfies by offering products that meet the daily needs of most users.

## Universal calipers

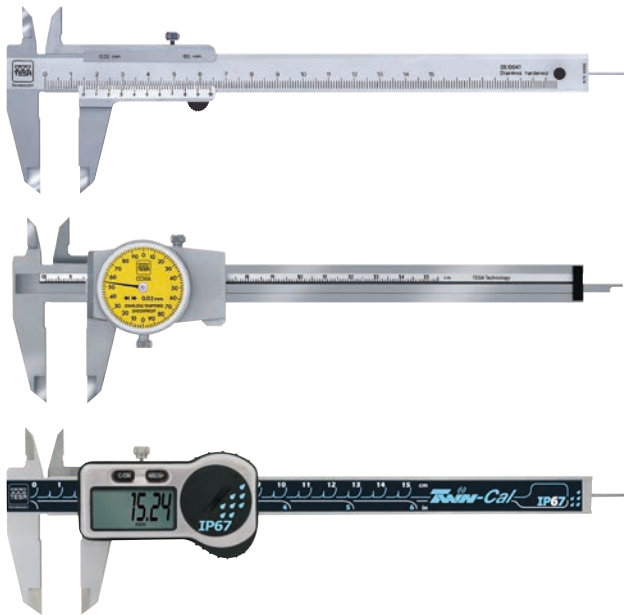

**Available versions:** vernier, dial, digital

## Workshop calipers



**Available versions:** vernier, digital

## Depth calipers



**Available versions:** vernier, digital

## Special calipers



**Available versions:** vernier, digital

# The security of a quality product

Since their development phase, TESA products are subject to strict internal standards aligned with the most restrictive national standards. Thanks to this close monitoring, all TESA instruments meet the quality requirements that we strive to keep as sharp as possible.



## Smooth operation of the slider

The beam of each instrument is specially lapped, in order to obtain a better than average sliding quality when compared to other instruments available on the market. Therefore, the flawless guide of the slider on the beam ensures a silky-smooth operation allowing more precise positioning whilst preventing the measuring jaws from tilting.



*High quality movement of the slider on the beam for an optimum user comfort.*

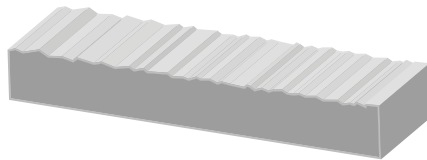

Lapped TESA beam

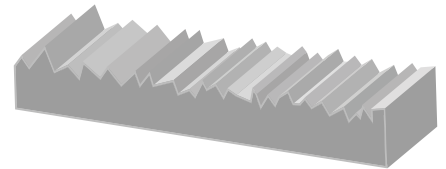

Ground beam



## Comfortable handling

Such instruments are generally used several times a day. Therefore, user comfort is definitely an important factor! Most of our instruments have an ergonomic grip for ease of use.



*The handling, display, buttons, slider, have been specially designed to allow a pleasant and reliable measurement.*



## A robust construction

All models incorporate industrially accepted materials perfectly suited to the production of traditional components. Since these instruments are usually used frequently, it is essential that their resistance is guaranteed for long term use. A judicious choice of material combined with appropriate thermal treatments, ensures high resistance to abrasion and corrosion.



*Workshop use requires stable components in order to guarantee long-term reliability of the instrument.*



## Stands up to the challenge

In harsh environments such as workshops, the instruments are often subject to all kinds of substances (oil, water, ...). Such conditions are not optimal for instruments containing electronic components. This is the reason why some of the digital models in the range have been designed with a high degree of protection (IP67) to guarantee the longevity of the instrument despite their exposure to various projections and intense solicitations.

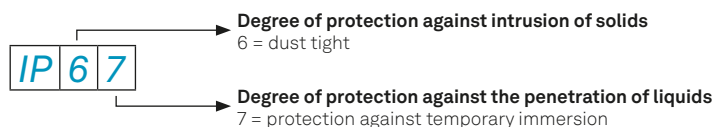

# Vernier caliper

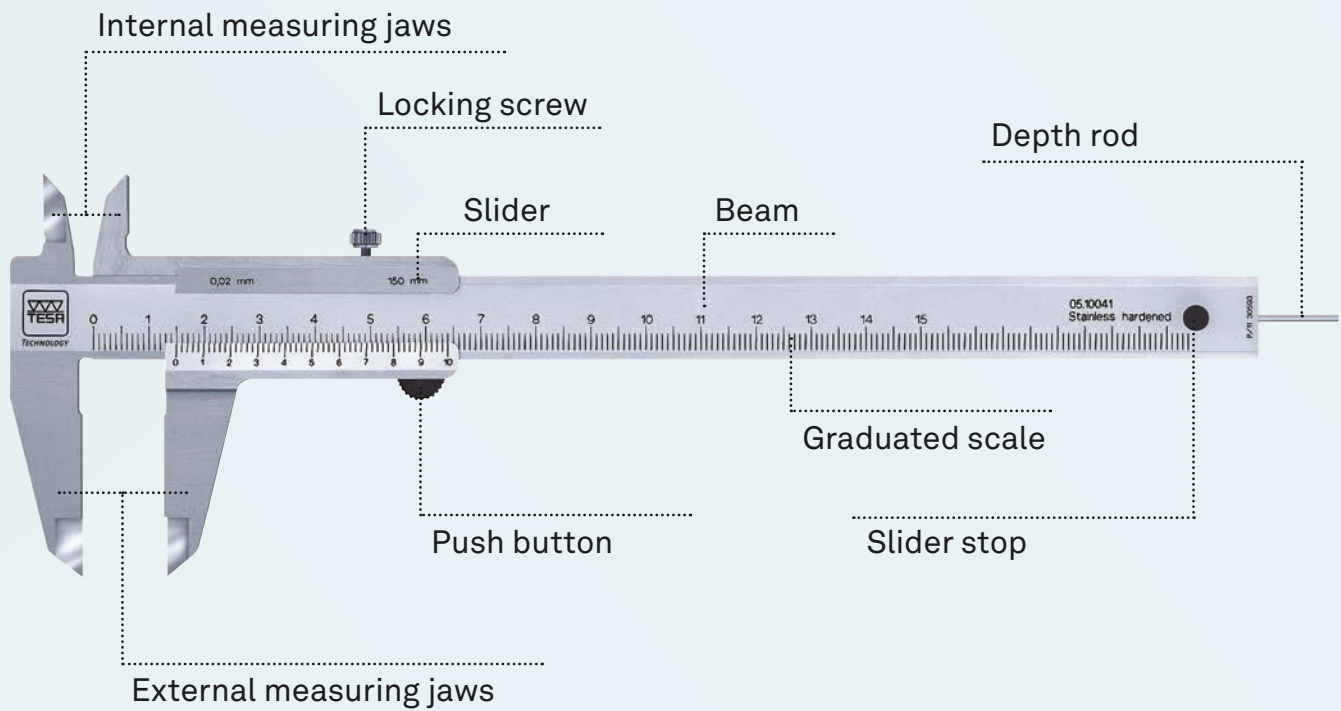

# Digital caliper

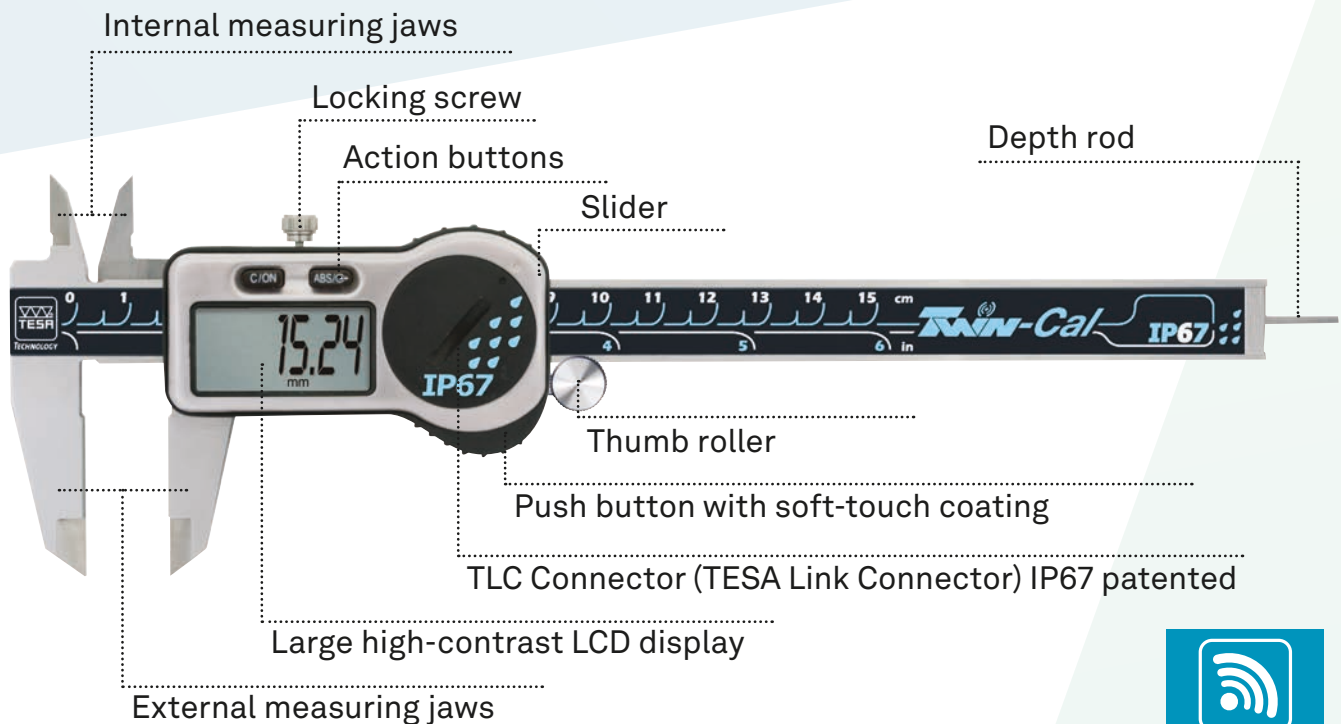

# Dial caliper

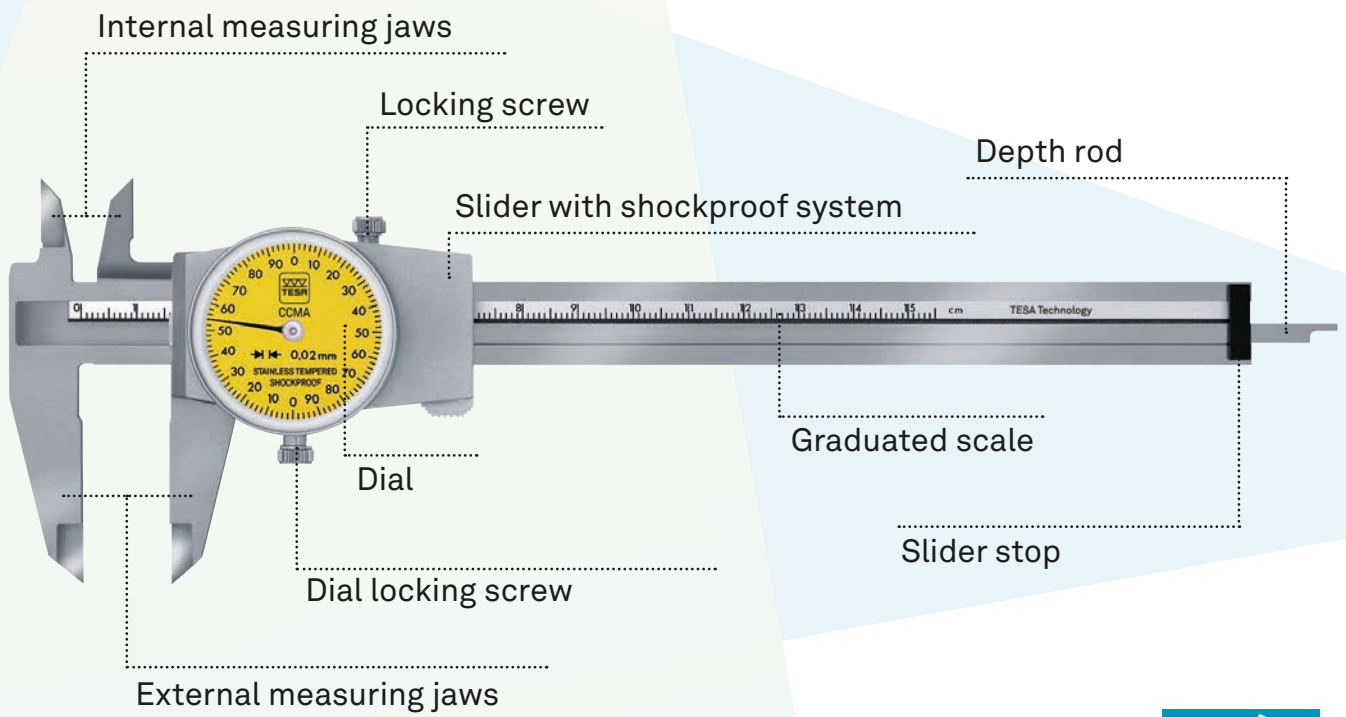



# Measurement examples

## Universal calipers

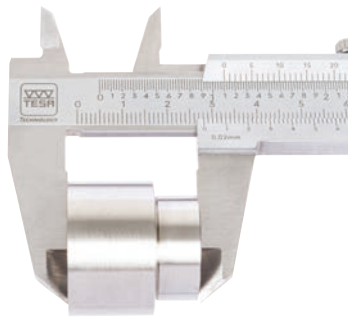

External measurement

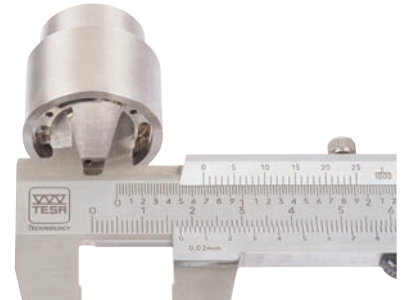

Internal measurement

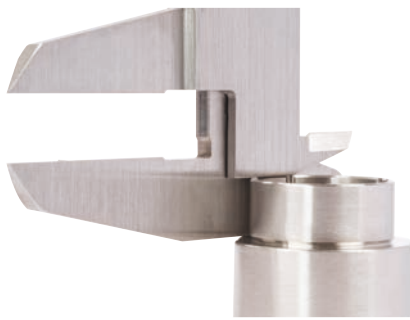
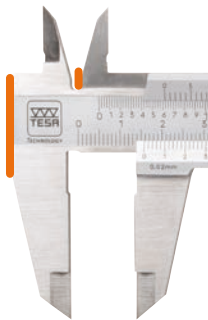

Step measurement

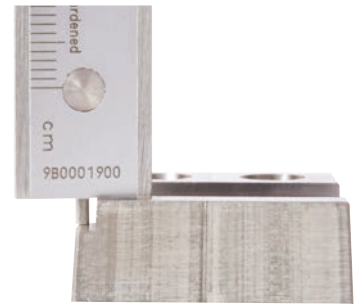

Depth measurement

## Workshop calipers

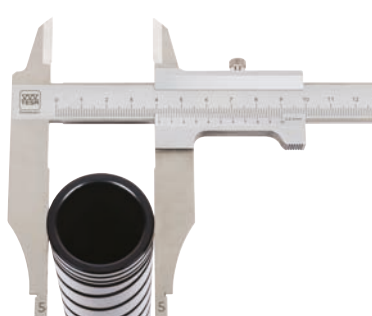

External measurement



Internal measurement

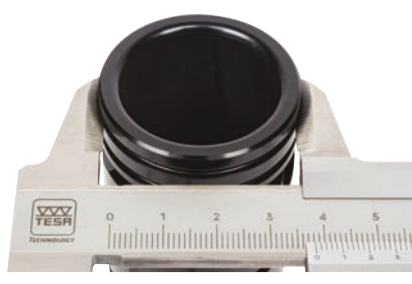
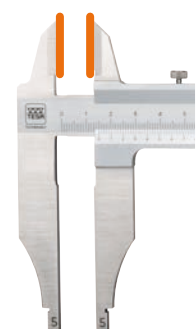

External measurement

## Depth calipers

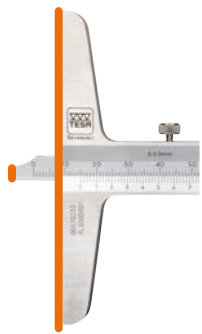

Measurement with short cut measuring face



Measurement with fixed hook



Measurement with tip



Measurement with rotary stop plate

## Special calipers



Groove measurement

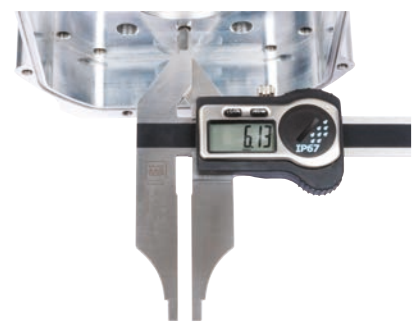

Internal measurement



Measurement with depth rod

# Data management



## With or without cable

Some of the digital calipers can be connected to a computer via the TLC (TESA Link Connector) on the front of the instrument. The purpose of this connection is to transmit the measured values to a software program for further processing. This connection can be made via cable or wireless.

Various output connector types are available. For more information, see the chapter on accessories.

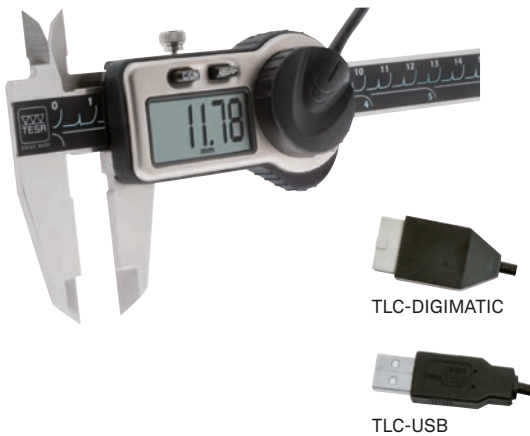

## Retrieve data with ease

The digital calipers, as well as most digital TESA instruments are compatible with the [free TESA DATA-VIEWER software](#), allowing a quick and easy handling of all measurement data in order to export the results to a data processing software or automatically create files in known formats such as \*.xls, \*.csv, or \*.txt.

The software can be downloaded free of charge from the [TESAtechnology.com](https://www.tesa-technology.com) website.







## Fill out a report template in real time

With **TESA DATA-DIRECT** software, it is possible to measure one or more mechanical parts and to automatically receive formatted data in a report template previously prepared (Excel for example). Once a measurement has been recorded, the report is directly accessible.

Slightly more advanced than the TESA DATA-VIEWER software, this software allows the programmed reception of data in a continuous way (data pooling). It also allows to automatically manage the cells subject to data reception (cell management).

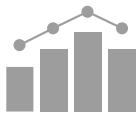

## The quick and easy statistical software

The SPC (Statistical Process Control) **TESA STAT-EXPRESS** software is an easy way to develop measurement programs from which all important statistical characteristics can be calculated in real time. Quick to learn, it manages also automatically the measuring reports.



## For demanding statistics

For users with more extensive needs, **Q-DAS** software will be able to meet the most specific requirements:

- Control and traceability
- Automated data recovery
- Setting up dashboards
- Quality management
- Optimization of production processes
- Supplier quality monitoring

# Maximum permissible error

















Measured length [mm]		Dial [μm]	Vernier [μm]			
from	to (including)	All resolutions	Universal		Workshop	
			0,02 mm	0,05 mm	0,02 mm	0,05 mm
0	10	±20	±30	±50	±30	±50
10	20	±20	±30	±50	±30	±50
20	30	±20	±30	±50	±30	±50
30	40	±20	±30	±50	±30	±50
40	50	±20	±30	±50	±30	±50
50	60	±20	±30	±50	±30	±50
60	70	±20	±30	±50	±30	±50
70	80	±20	±30	±50	±30	±50
80	100	±20	±30	±50	±30	±50
100	150	±30	±30	±50	±30	±50
150	200	±30	±30	±50	±30	±50
200	250	±30	±40	±50	±30	±50
250	300	±30	±40	±50	±40	±50
300	400	–	–	–	±40	±60
400	500	–	–	–	±50	±70
500	600	–	–	–	–	–
600	1000	–	–	–	–	–

All the values in this table are valid for measurements carried out without reversal of the measuring force and with a fixed zero. For all other types of measurements (e.g. using the internal jaws) and those carried out with the depth foot, the values in the table increase by 20 μm.



Vernier [μm]			Digital [μm]			
	Depth 0,02 mm	Depth 0,05 mm	For grooves	Universal 0,01 mm	Workshop 0,01 mm	Depth 0,01 mm
	±30	±50	See product page	±20	±30	±20
	±30	±50		±20	±30	±20
	±30	±50		±20	±30	±20
	±30	±50		±20	±30	±20
	±30	±50		±20	±30	±20
	±30	±50		±20	±30	±20
	±30	±50		±20	±30	±20
	±30	±50		±20	±30	±20
	±30	±50		±20	±30	±20
	±40	±50		±20	±30	±20
	±40	±50		±30	±40	±30
	±40	±50		±30	±40	±30
	±40	±50		±30	±40	±30
	±40	±50		±30	±40	±30
	±50	±50		±30	±40	±30
	±50	±50		±30	±40	±30
	-	-		±40	±40	±40
	-	-		±50	±40	±40



Family		Universal		Workshop	Depth	Special
	Type	TESA-CAL	TWIN-CAL	TWIN-CAL	TWIN-CAL	TWIN-CAL
	Buttons	2	2	2	2	2
	Mode ABS	•	•	•	•	•
	Mode DIFF	•	•	•	•	•
	Zero-setting	•	•	•	•	•
	Resolution (0,01 mm / 0.0005 in)	•	•	•	•	•
	Display mm/in	•	•	•	•	•
	Large high-contrast display	•	•	•	•	•
	LCD, 11 mm	•	•	•	•	•
	Automatic sleep mode	•	•	•	•	•
	Data transmission via cable		•	•	•	•
	Wireless data transmission		•	•	•	•
	Low battery indicator	•	•	•	•	•
	OK/NOK* Function		•	•	•	•

\* when using with TESA STAT-EXPRESS software



# Universal dial models



00510050



00510004



00510008

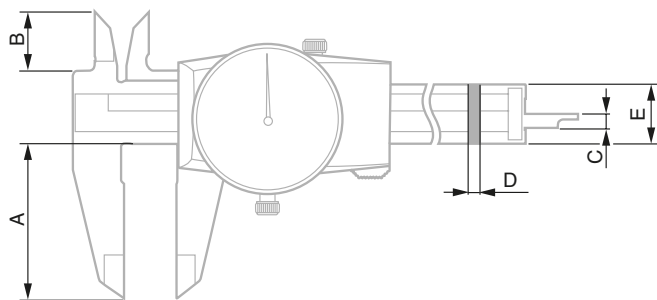

ISO 13385-1:2019



Hardened stainless steel  
Gear mechanism  
made of hardened,  
ground steel



Patented shockproof  
system



Rotating dial  $\varnothing 32$  mm  
with locking screw





Locking screw  
of the slider

Part number	Measuring range [mm]	Resolution [mm]	[mm]/revolution	Thumb roller	Housing	A [mm]	B [mm]	C [mm]	D [mm]	E [mm]
00510050	150	0,01	1	–	metal	40	13	1,5 x 1,9	3,2	15,5
075115821	150	0,02	1	–	metal	40	13	1,5 x 1,9	3,2	15,5
00510008	150	0,02	2	–	metal	40	13	1,5 x 1,9	3,2	15,5
00510004	150	0,02	2	–	plastic	40	13	1,5 x 1,9	3,2	15,5
00510045	200	0,02	2	●	metal	50	18,6	1,5 x 1,9	3,6	15,5
00510046	300	0,02	2	●	metal	64	20,6	1,5 x 1,9	4	15,5



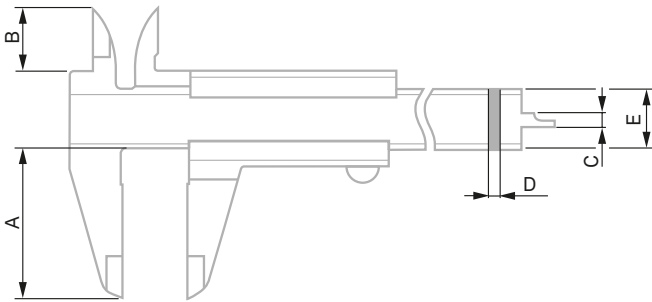
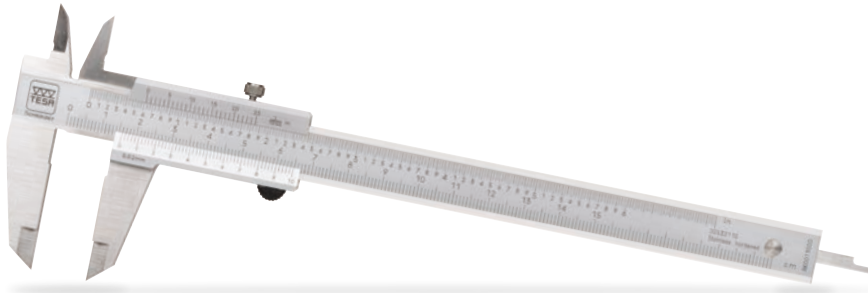

# Universal vernier models



 ISO 13385-1:2019

 Hardened stainless steel

 Satin-chrome scale background

 Main scale slightly set back for protection against wear

 Locking screw of the slider

Part number	Measuring range		Resolution		Self-locking	A	B	C	D	E
	[mm]	[in]	[mm]	[in]		[mm]	[mm]	[mm]	[mm]	[mm]
00510070	150		0,02		–	40	21	1,5 x 2	3	16
00530110	150	6	0,02	.001	–	40	21	1,5 x 2	3	16
00530121	150	6	0,02	.001	●	40	21	1,5 x 2	3	16
00510073	150		0,05		–	40	21	1,5 x 2	3	16
00530103	150	6	0,05	1/128	–	40	21	1,5 x 2	3	16
00530120	150	6	0,05	1/128	●	40	21	1,5 x 2	3	16
00510071	200		0,02		–	50	23,5	1,5 x 2	3,5	17
00530111	200	8	0,02	.001	–	50	23,5	1,5 x 2	3,5	17
00510074	200		0,05		–	50	23,5	1,5 x 2	3,5	17
00530104	200	8	0,05	1/128	–	50	23,5	1,5 x 2	3,5	17
00510072	300		0,02		–	64	27,5	1,5 x 2	4	20
00530112	300	12	0,02	.001	–	64	27,5	1,5 x 2	4	20
00510075	300		0,05		–	64	27,5	1,5 x 2	4	20
00530105	300	12	0,05	1/128	–	64	27,5	1,5 x 2	4	20

# Universal digital models



Data transmission



IP67, without data transmission



IP67, Data transmission

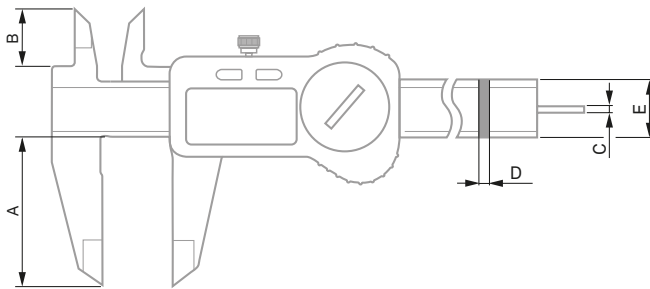

ISO 13385-1:2019



Hardened stainless steel



LCD, 11 mm



Resolution  
0,01 mm / .0005 in



Data transmission  
(via cable or wireless)



Locking screw  
of the slider

Part number	Measuring range		Degree of protection	Thumb roller	Data transmission	A	B	C	D	E
	[mm]	[in]				[mm]	[mm]	[mm]	[mm]	[mm]
00530094	150	6		●	●	40	16	∅1,5	3,2	15,5
00530097	150	6		–	●	40	16	1,3 x 1,7	3,2	15,5
00530140	150	6	IP67	–	–	40	16	1,3 x 1,7	3,2	15,5
00530141	150	6	IP67	–	–	40	16	∅1,5	3,2	15,5
00530319	150	6	IP67	–	●	40	16	1,3 x 1,7	3,2	15,5
00530320	150	6	IP67	–	●	40	16	∅1,5	3,2	15,5
00530321	150	6	IP67	●	●	40	16	∅1,5	3,2	15,5
00530095	200	8		●	●	50	20	1,3 x 1,7	3,6	15,5
00530142	200	8	IP67	●	–	50	20	1,3 x 1,7	3,6	15,5
00530322	200	8	IP67	●	●	50	20	1,3 x 1,7	3,6	15,5
00530096	300	12		●	●	64	22	1,3 x 1,7	4	15,5
00530143	300	12	IP67	●	–	64	22	1,3 x 1,7	4	15,5
00530323	300	12	IP67	●	●	64	22	1,3 x 1,7	4	15,5

# Workshop vernier models

## with rounded internal measuring faces

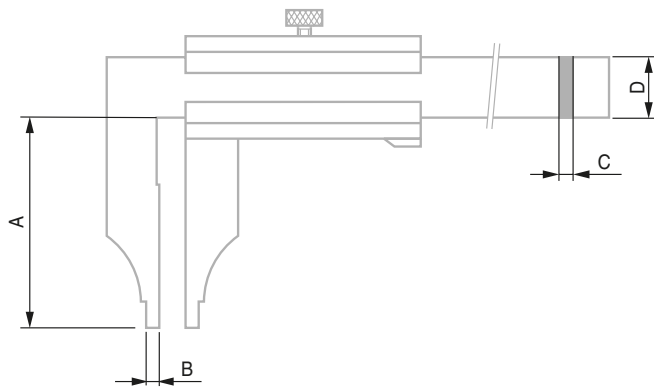
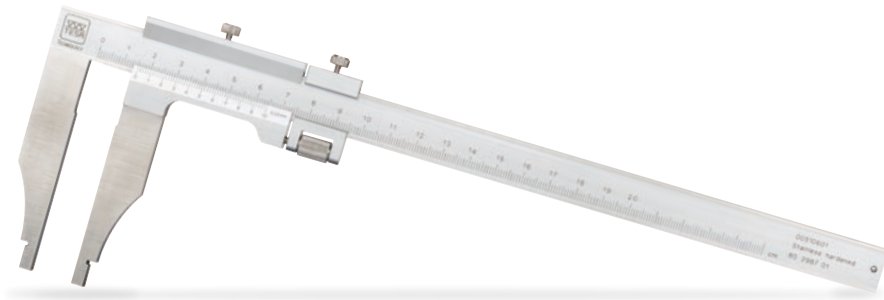

ISO 13385-1:2019



Hardened stainless steel



Satin-chrome scale background



Main scale slightly set back for protection against wear



Locking screw of the slider

Part number	Measuring range		Resolution		Fine adjustment	A	B	C	D
	[mm]	[in]	[mm]	[in]					
00510509	200		0,02		–	60	5	3,5	17
00510601	200		0,02		●	60	5	3,5	17
00510506	200		0,05		–	60	5	3,5	17
00510602	200		0,05		●	60	5	3,5	17
00530506	200	8	0,05	1/128	–	60	5	3,5	17
00530602	200	8	0,05	1/128	●	60	5	3,5	17
00510521	300		0,02		–	90	5	4	20
00510621	300		0,02		●	90	5	4	20
00510522	300		0,05		–	90	5	4	20
00510622	300		0,05		●	90	5	4	20
00530522	300	12	0,05	1/128	–	90	5	4	20
00530622	300	12	0,05	1/128	●	90	5	4	20
00510541	500		0,02		–	150	10	6	28
00510641	500		0,02		●	150	10	6	28
00510542	500		0,05		–	150	10	6	28
00510642	500		0,05		●	150	10	6	28
00530542	500	20	0,05	1/128	–	150	10	6	28
00530642	500	20	0,05	1/128	●	150	10	6	28

# Digital workshop models

with rounded internal measuring faces

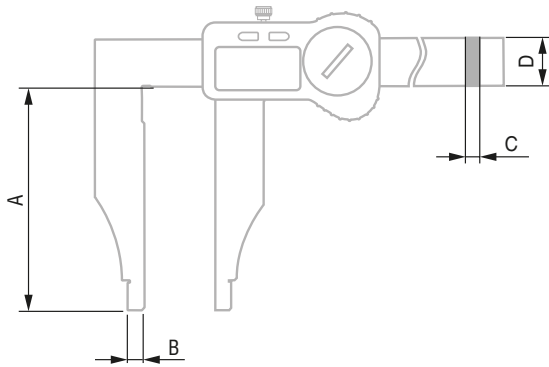

ISO 13385-1:2019



Hardened stainless steel



LCD, 11 mm



Resolution  
0,01 mm / .0005 in



Data transmission  
(via cable or wireless)



Locking screw  
of the slider

Part number	Measuring range		Degree of protection	Data transmission	A	B	C	D
	[mm]	[in]			[mm]	[mm]	[mm]	[mm]
00530421	200	8	IP67	●	80	5	4	20
00530422	250	10	IP67	●	80	5	4	20
00530423	300	12	IP67	●	80	5	4	20
00530424	500	20	IP67	●	150	10	4	28
00530425	600	24	IP67	●	150	10	4	28
00530426	800	32	IP67	●	150	10	4	32
00530427	1000	39	IP67	●	150	10	4	32

# Workshop vernier models

with rounded internal measuring faces  
and knife-edge external jaws

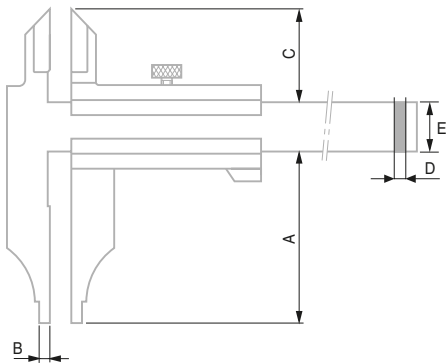

ISO 13385-1:2019



Hardened stainless steel



Satin-chrome  
scale background



Main scale slightly set  
back for protection  
against wear



Locking screw  
of the slider

Part number	Measuring range		Resolution		Fine adjustment	A	B	C	D	E
	[mm]	[in]	[mm]	[in]						
00510701	200		0,02		–	60	5	30	3,5	17
00510801	200		0,02		●	60	5	30	3,5	17
00510702	200		0,05		–	60	5	30	3,5	17
00510802	200		0,05		●	60	5	30	3,5	17
00530702	200	8	0,05	1/128	–	60	5	30	3,5	17
00530802	200	8	0,05	1/128	●	60	5	30	3,5	17
00510721	300		0,02		–	90	5	38	4	20
00510821	300		0,02		●	90	5	38	4	20
00510722	300		0,05		–	90	5	38	4	20
00510822	300		0,05		●	90	5	38	4	20
00530722	300	12	0,05	1/128	–	90	5	38	4	20
00530822	300	12	0,05	1/128	●	90	5	38	4	20
00510741	500		0,02		–	150	10	60	6	28
00510841	500		0,02		●	150	10	60	6	28
00510742	500		0,05		–	150	10	60	6	28
00510842	500		0,05		●	150	10	60	6	28
00530742	500	20	0,05	1/128	–	150	10	60	6	28
00530842	500	20	0,05	1/128	●	150	10	60	6	28





# Digital workshop models

with rounded internal measuring faces  
and knife-edge external jaws

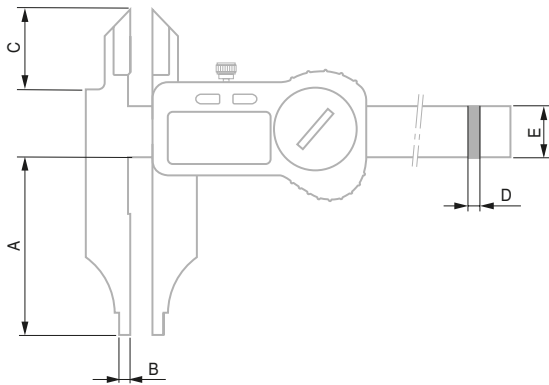

ISO 13385-1:2019



Hardened stainless steel



LCD, 11 mm



Resolution  
0,01 mm / .0005 in



Data transmission  
(via cable or wireless)



Locking screw  
of the slider

Part number	Measuring range		Degree of protection	Data transmission	A [mm]	B [mm]	C [mm]	D [mm]	E [mm]
	[mm]	[in]							
00530431	200	8	IP67	●	80	5	30	4	20
00530432	250	10	IP67	●	80	5	37	4	20
00530433	300	12	IP67	●	80	5	37	4	20
00530434	500	20	IP67	●	150	10	60	4	28
00530435	600	24	IP67	●	150	10	60	4	28
00530436	800	32	IP67	●	150	10	56	4	32
00530437	1000	39	IP67	●	150	10	56	4	32

# Vernier depth models

## with short cut measuring face

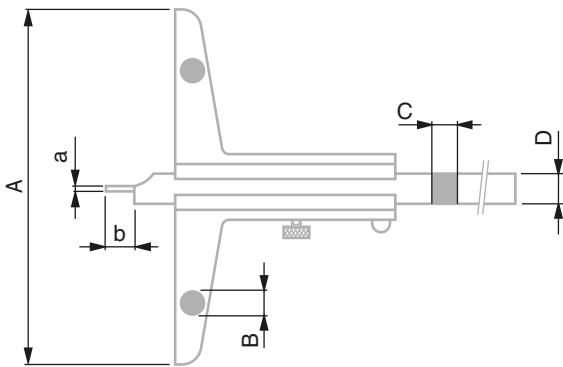

ISO 13385-1:2019



Hardened stainless steel



Satin-chrome  
scale background



Main scale slightly set  
back for protection  
against wear



Locking screw  
of the slider

Part number	Measuring range [mm]	Resolution [mm]	Steel measuring tip	A [mm]	B [mm]	C [mm]	D [mm]	a [mm]	b [mm]
00510233	150	0,02	–	100	6,5	3	8		
00510234	150	0,05	–	100	6,5	3	8		
00510223	150	0,02	●	100	6,5	3	8	Ø1,5	8
00510224	150	0,05	●	100	6,5	3	8	Ø1,5	8
00510243	200	0,02	–	100	6,5	3	8		
00510244	200	0,05	–	100	6,5	3	8		
00510225	200	0,02	●	100	6,5	3	8	Ø1,5	8
00510226	200	0,05	●	100	6,5	3	8	Ø1,5	8
00510253	300	0,02	–	150	8	4	12		
00510254	300	0,05	–	150	8	4	12		
00510227	300	0,02	●	150	8	4	12	Ø2	8
00510228	300	0,05	●	150	8	4	12	Ø2	8
00510263	500	0,02	–	150	8	4	12		
00510264	500	0,05	–	150	8	4	12		

# Digital depth models

## with short cut measuring face



ISO 13385-1:2019



Hardened stainless steel



LCD, 11 mm



Resolution  
0,01 mm / .0005 in



Data transmission  
(via cable or wireless)



Locking screw  
of the slider

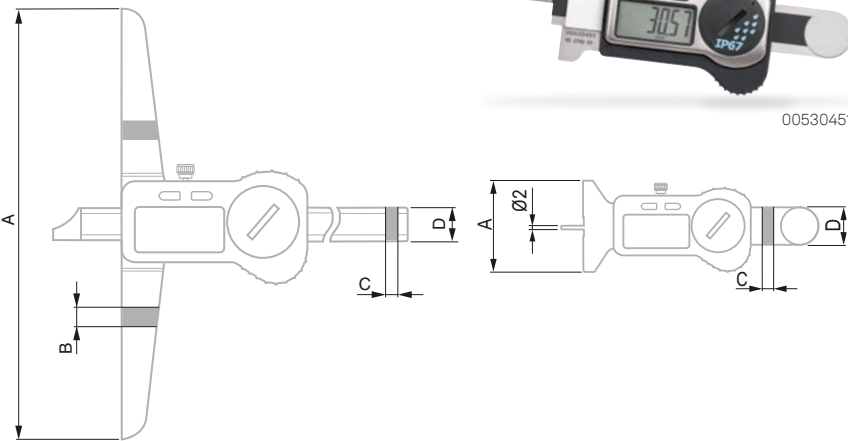

Part number	Measuring range		Degree of protection	Steel measuring tip	Data transmission	A [mm]	B [mm]	C [mm]	D [mm]
	[mm]	[in]							
00530441	200	8	IP67	-	●	100	8	4	15
00530442	250	10	IP67	-	●	100	8	4	15
00530443	300	12	IP67	-	●	150	8	4	15
00530444	500	20	IP67	-	●	150	8	4	15
00530451	25	1	IP67	●	●	50	-	4	20

# Vernier depth models

## with fixed hook



ISO 13385-1:2019



Hardened stainless steel



Satin-chrome  
scale background



Main scale slightly set  
back for protection  
against wear



Locking screw  
of the slider

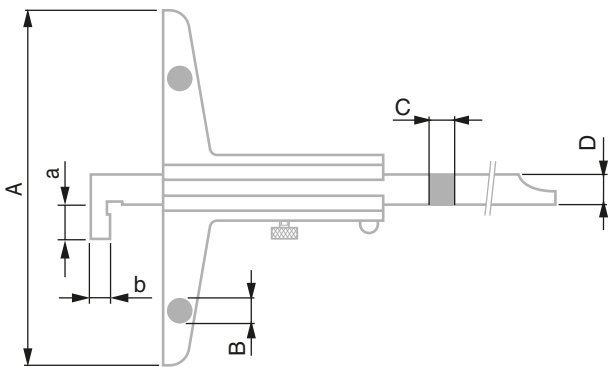

Part number	Measuring range [mm]	Resolution [mm]	Number of hooks	A [mm]	B [mm]	C [mm]	D [mm]	a [mm]	b [mm]
00510275	150	0,02	1	100	6,5	3	8	12	5
00510276	150	0,05	1	100	6,5	3	8	12	5
00510277	200	0,02	1	100	6,5	3	8	12	5
00510278	200	0,05	1	100	6,5	3	8	12	5
00510279	300	0,02	1	150	8	4	10	16	10
00510280	300	0,05	1	150	8	4	10	16	10
00510281	500	0,02	1	150	8	4	10	16	10
00510282	500	0,05	1	150	8	4	10	16	10

# Digital depth models

## with fixed hooks



ISO 13385-1:2019



Hardened stainless steel



LCD, 11 mm



Resolution  
0,01 mm / .0005 in



Data transmission  
(via cable or wireless)



Locking screw  
of the slider

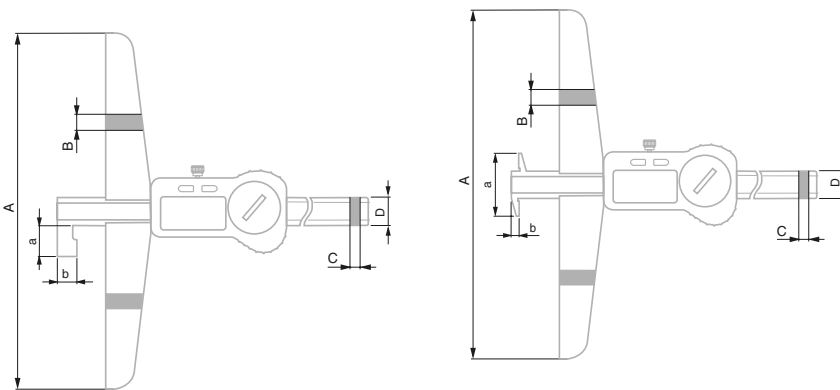

Part number	Measuring range		Degree of protection	Data transmission	Number of hooks	A	B	C	D	a	b
	[mm]	[in]				[mm]	[mm]	[mm]	[mm]	[mm]	[mm]
00530445	300	12	IP67	●	1	150	8	4	15	15,5	10
00530447	300	12	IP67	●	2	150	8	4	15	27,5	5
00530446	500	20	IP67	●	1	150	8	4	15	15,5	10



# Vernier depth models

## with rotary stop plate



ISO 13385-1:2019



Hardened stainless steel



Satin-chrome  
scale background



Main scale slightly set  
back for protection  
against wear



Locking screw  
of the slider

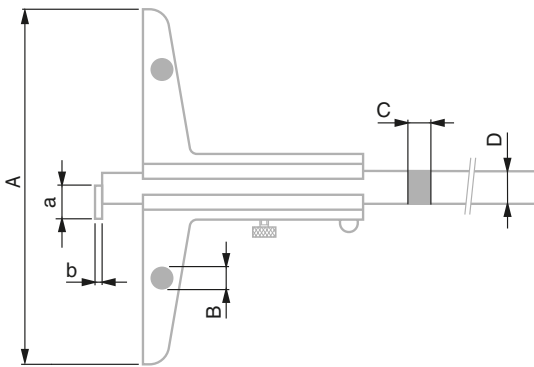

Part number	Measuring range [mm]	Resolution [mm]	A [mm]	B [mm]	C [mm]	D [mm]	a [mm]	b [mm]
00510291	150	0,02	150	8,5	4	12	5,3	2
00510292	150	0,05	150	8,5	4	12	5,3	2
00510293	250	0,02	150	8,5	4	12	5,3	2
00510294	250	0,05	150	8,5	4	12	5,3	2
00510295	500	0,02	150	8,5	4	12	5,3	2
00510296	500	0,05	150	8,5	4	12	5,3	2

# Digital depth models

## with rotary stop plate

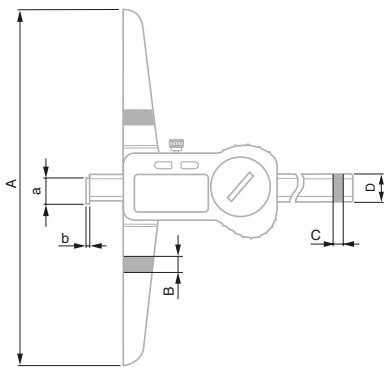

ISO 13385-1:2019



Hardened stainless steel



LCD, 11 mm



Resolution  
0,01 mm / .0005 in



Data transmission  
(via cable or wireless)



Locking screw  
of the slider

Part number	Measuring range		Degree of protection	Data transmission	A	B	C	D	a	b
	[mm]	[in]			[mm]	[mm]	[mm]	[mm]	[mm]	[mm]
00530448	250	10	IP67	●	150	8,5	4	15	15,7	2
00530449	350	14	IP67	●	150	8,5	4	15	15,7	2
00530450	500	20	IP67	●	150	8,5	4	15	15,7	2

# Special vernier models

## for groove measurement



 ISO 13385-1:2019

 Hardened stainless steel

 Satin-chrome scale background

 Main scale slightly set back for protection against wear

 Locking screw of the slider

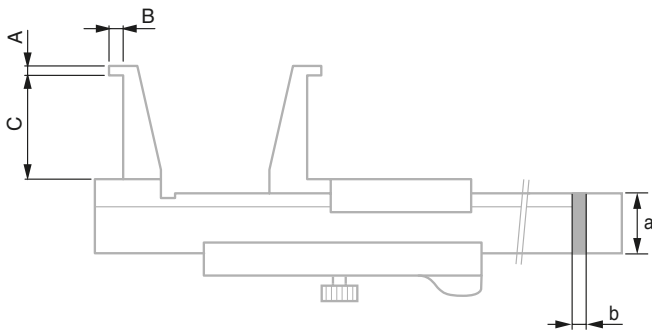

Part number	Measuring range [mm]	Resolution [mm]	MPE <sub>E</sub> [μm]	A [mm]	B [mm]	C [mm]	a [mm]	b [mm]
00510371	10 ÷ 160	0,05	±50	0,9	3	25	16	3
00510375	20 ÷ 160	0,05	±50	2,0	5	40	16	3
00510383	26 ÷ 200	0,02	±80	3,0	7	60	16	3
00510387	30 ÷ 250	0,02	±100	4,0	8,5	80	20	4
00510393	35 ÷ 300	0,02	±120	5,0	10	100	20	4

# Special digital model

with rounded internal measuring faces  
and knife-edge internal jaws

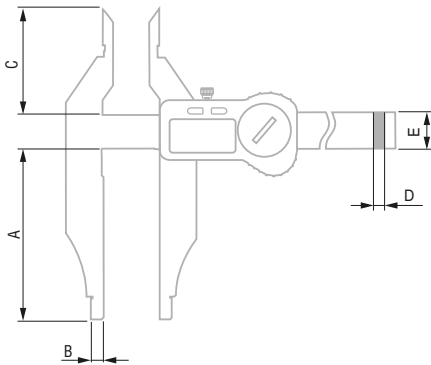

ISO 13385-1:2019



Hardened stainless steel



LCD, 11 mm



Resolution  
0,01 mm / .0005 in



Data transmission  
(via cable or wireless)



Locking screw  
of the slider

Part number	Measuring range		Degree of protection	Data transmission	A	B	C	D	E
	[mm]	[in]			[mm]	[mm]	[mm]	[mm]	[mm]
00530430	250	10	IP67	●	80	5	54	4	20

# Accessories

Part number	Description	Notes
00560013	Depth foot	For universal digital calipers of 150 mm
00560055	Depth foot	For universal vernier calipers of 150 mm
00560106	Thumb roller	For universal calipers TWIN-CAL 150 mm
01961000	Lithium battery 3 V, CR2032	For digital instruments
0051610365	Magnetic magnifying glass, 3x magnification	For vernier instruments
00560103	Removable bridge, 200 mm	For digital depth calipers of 150 mm
00560104	Removable bridge, 300 mm	For digital depth calipers of 150 mm
00560105	Removable bridge, 400 mm	For digital depth calipers of 150 mm
00560108	Removable bridge, 180 mm	For vernier depth calipers, starting from 250 mm
00560109	Removable bridge, 260 mm	For vernier depth calipers, starting from 250 mm
00560110	Removable bridge, 320 mm	For vernier depth calipers, starting from 250 mm
-	TESA DATA-VIEWER software	Downloadable free of charge from the TESA website
04981001	TESA DATA-DIRECT software	For data formatting
04981002	TESA STAT-EXPRESS software	SPC software
-	Q-DAS (qs-STAT,...) software	Please contact your local dealer
04760182	TLC-DIGIMATIC cable	-
04760181	TLC-USB cable	-
04760184	Emitter TLC-BLE (Bluetooth®)	-
04760185	Dongle + 1,5 m cable	For use with 04760184
04760183	Starter kit	= 04760184 + 04760185

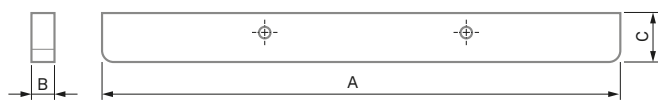
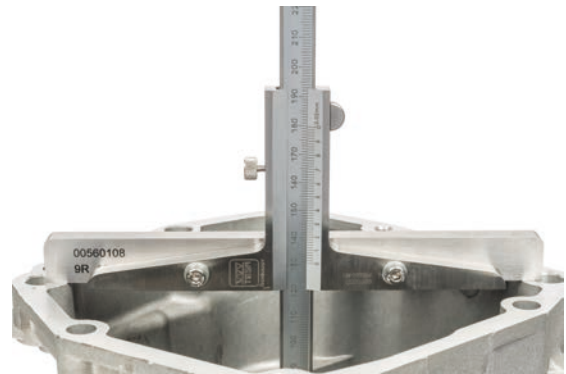
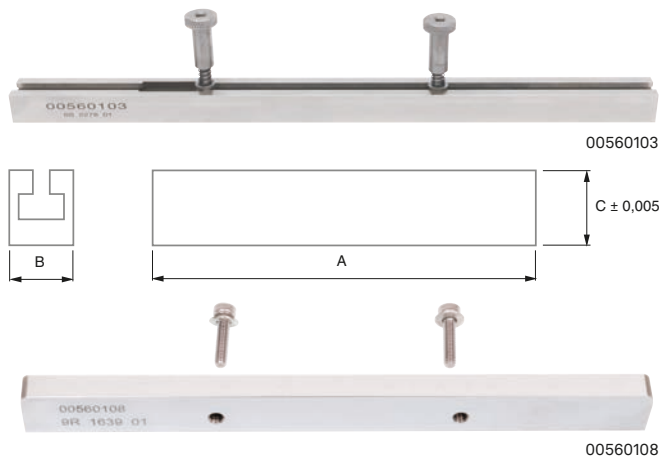

Part number	A [mm]	B [mm]	C [mm]
00560103	200	11,5	10
00560104	300	16	16
00560105	400	16	16
00560108	180	8	17
00560109	260	8	17
00560110	320	8	17





00560106



00560013

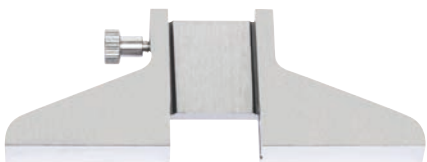
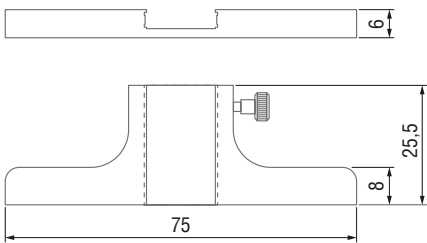

00560055

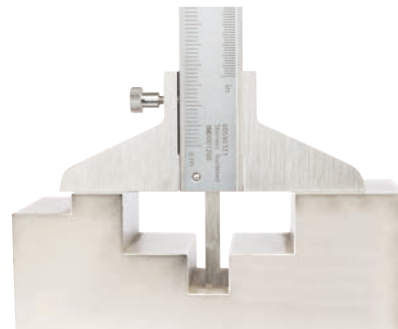
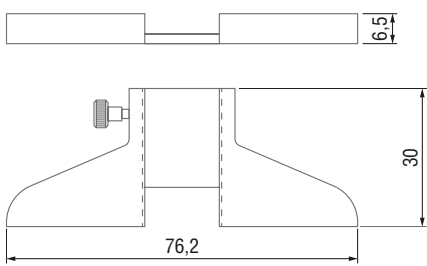

0051610365

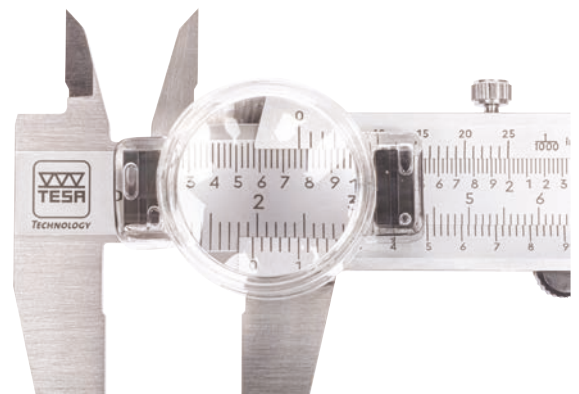

# Accessories



04760181



04760182



04760183



04760185



04760184



# The TESA service, our priority

For TESA, customer care is essential. To satisfy the most demanding metrological expectations of our clients and to help them find solutions is our daily challenge.



## Calibration

To preserve the accuracy of measurement of your tools, TESA controls and calibrates your equipment on request and can provide a certificate in accordance with ISO 17025.

---



## Repairs

Your instrument needs to be repaired? TESA proposes quick solutions to repair, exchange and rent, if your equipment is under warranty or not.

---



## Support

A product support and technical support are available for TESA equipment.

---



## Training

A whole range of courses has been designed to meet your needs: user training during the installation, product training at TESA headquarters as well as on-site and customised trainings.

---



## Customisation

For any requirements of specific measures, that you cannot find in our catalogue, you can contact our specialists to design a customised solution.





**HEXAGON**

Hexagon Manufacturing Intelligence helps industrial manufacturers develop the disruptive technologies of today and the life-changing products of tomorrow. As a leading metrology and manufacturing solution specialist, our expertise in sensing, thinking and acting – the collection, analysis and active use of measurement data – gives our customers the confidence to increase production speed and accelerate productivity while enhancing product quality.

Through a network of local service centres, production facilities and commercial operations across five continents, we are shaping smart change in manufacturing to build a world where quality drives productivity. For more information, visit [HexagonMI.com](https://www.hexagonmi.com).

Hexagon Manufacturing Intelligence is part of Hexagon (Nasdaq Stockholm: HEXA B; [hexagon.com](https://www.hexagon.com)), a leading global provider of information technologies that drive quality and productivity across geospatial and industrial enterprise applications.

-  COORDINATE MEASURING MACHINES
-  3D LASER SCANNING
-  SENSORS
-  PORTABLE MEASURING ARMS
-  SERVICES
-  LASER TRACKERS & STATIONS
-  MULTISENSOR & OPTICAL SYSTEMS
-  WHITE LIGHT SCANNERS
-  METROLOGY SOFTWARE SOLUTIONS
-  CAD / CAM
-  STATISTICAL PROCESS CONTROL
-  AUTOMATED APPLICATIONS
-  MICROMETERS, CALIPERS, HEIGHT GAGES, ETC...
-  DESIGN AND COSTING SOFTWARE



Established in 1941 and headquartered in Renens, Switzerland, TESA manufactures and markets precision measuring instruments that stand for quality, reliability and longevity.

For more than 75 years, TESA has distinguished itself in the market through its excellent products, its unique expertise in micromechanics and precision machining as well as its proven experience in dimensional metrology.

The TESA brand is the global market leader in the field of height gauges and a pioneer thanks to its wide range of instruments, including callipers, micrometers, dial gauges,

lever-type dial test indicators and inductive probes. TESA is a true benchmark for the inspection of incoming goods, as well as for production workshops and quality assurance laboratories.

Through its worldwide distribution network the company focuses on the mechanical engineering, micromechanical, automotive, aerospace, watchmaking and medical industries. In 2001, TESA became part of Hexagon, a leading global provider of information technologies.

[TESAtechnology.com](https://www.tesatechnology.com)