

P-LINE PERPENDICULAR

Resolution 0.01 mm	01810408 (222GL)
Measuring range (mm)	3
Resolution (mm)	0.01
Dial, Ø (mm)	40
Stroke/revolution (mm)	1
Circular scale	0 ÷ 50 ÷ 100
Measuring insert length (mm)	36
Indication error over the measurement range (plunger retractable and extendable) MPE _{tot} (µm)	26
Indication error over the measurement range (retractable plunger) MPEE (µm)	20
Partial indication error (over 1 revolution) MPEP (µm)	12
Partial indication error (over 1/2 revolution) MPEP (µm)	10
Partial indication error (over 1/10 revolution) MPEP (µm)	3
Hysteresis of the indication error MPEH (µm)	7
Repeatability of the indication error MPER (µm)	3
Measurement force (N)	0.2

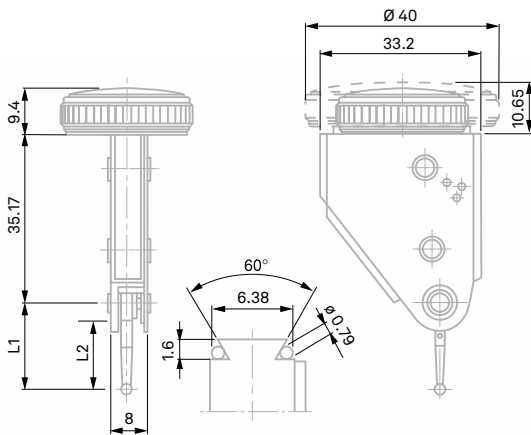

L1 and L2, see table of measuring insert, p. 12



222GL

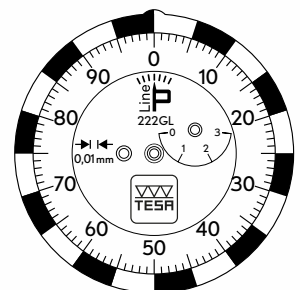

01810408